

MPI160HD

TECHNICAL DESCRIPTION

1 GENERAL DESCRIPTION

The MPI160HD system is designed to convert AC mains voltage into 48 VDC and to supply telecom equipment with battery back up time.

The MPI160HD can house up to eight SMi2000HD rectifier modules and can be connected to up to eight 48V valve regulated lead-acid (VRLA) battery strings.

The total power installed is 16kW but the total load power available is 13kW max ("PCB" and "battery shunt" design limited).



The MPI160HD is fitted with:

- Wiring and locations for up to eight SMi2000HD rectifier modules,
- 4 Rectifier motherboards,
- 1 ACMi1000HD alarm and control module,
- 1 Interface board,
- 2 Battery and load shunts PCB,
- 1 Low voltage disconnect contactor (LVD : 250A rated),
- Location for battery fuses or circuit breakers protection,
- Location for protection single pole fuses or circuit breakers,
- Location for option,
- A temperature probe.

The maximum DC current available depends on the number of installed SMi2000HD rectifiers. Refer to the SMi2000HD technical description.

The MPI160HD can be installed on the top of battery rack, wall mounted or in a 19" cabinet.

The system allows an easy extension on site by additional battery string(s) and rectifier module(s).

MPI160HD TECHNICAL DESCRIPTION

2 STANDARDS

Safety	CE Low Voltage IEC 60950-1 UL 60950-1 compliant (pending) CSA 22.2
EMC	CE EMC Directives
Emission :	
Conducted	EN55022 class B
Radiated	EN55022 class B
Immunity :	
ESD	IEC/EN61000-4-2
Radiated 'E' field	IEC/EN61000-4-3
Fast transient	IEC/EN61000-4-4
Surge	IEC/EN61000-4-5
Conducted RF	IEC/EN61000-4-6
Radiated 'H' field	IEC/EN61000-4-8
Power Line Dips	IEC/EN61000-4-11
'ANSI' Surge	IEEE C62.41
Harmonics	IEC/EN61000-3-2
Flickers	IEC/EN61000-3-3
Telecom networks	ETSI EN 300 132-2 EN 300 386-2
Environment	ETSI EN 300 019-2 RoHs compliant

MPI160HD TECHNICAL DESCRIPTION

3 CHARACTERISTICS

3.1 ENVIRONMENTAL CHARACTERISTICS

Temperature	
Operating	- 20°C to + 70°C. (start up to – 40°C)
Shipping and storage	- 40°C to + 85°C
Relative humidity	
Operating	5 to 95% RH non-condensing
Storage	5 to 95% RH non-condensing (not exceed 40g water vapour / m ³ of air)
Cooling	Natural convection
Altitude	- 60 m to + 2500 m

3.2 MECHANICAL CHARACTERISTICS

	Core + 1 extension 8U	Core + 2 extensions 12U
Height	372 mm	550 mm
Width	447 mm	
Depth	435 mm	
Weight	25 kg*	35 kg*
Access	Front and top	
Cable entry	Rear	
Degree of protection	IP20	

*pending options

3.3 ELECTRICAL CHARACTERISTICS

AC Input	
Nominal Voltage	Single phase 230V AC Three phases + neutral 400V AC
Voltage range	
Full power	180 to 300V AC
Reduced power	90 to 180V AC
Frequency Range	45 to 66Hz
Maximum current	See SMi2000HD technical description
Protection	See SMi2000HD technical description

DC Output	
Nominal voltage	48V DC
Output power rating	Depending number of SMi2000HD (see SMi2000HD technical description)
Protection	
SMi2000HD System	See SMi2000HD technical description Battery and load MCB protection

Other specifications	
Dielectric strength	4.2kV DC (3.0kV AC) – Input and output
	2.1kV DC (1.5kV AC) – Input and earth
	0.7kV DC (0.5kV AC) – Output and earth

Monitoring	
Controller unit	See ACMi1000HD technical description
Main Functionalities	Control and monitoring on digital rectifier module Battery charging process Battery test Battery protection Load management Alarm detection and reporting Communication for monitoring and configuration Local Man / Machine Interface for monitoring and configuration.
Local	Menu managed by joystick and LCD display and PC (Wini1000)
Visual indications	
SMi2000HD System	See SMi2000HD technical description See ACMi1000HD technical description
Digital input spare	2
Alarm relays	3 configurable relays
Measurements	Load current Battery current Ambient temperature Load voltage Battery voltage
Main Alarms	Low or high Mains voltage alarm Rectifier alarm Load protection alarm Battery protection alarm Low battery voltage alarm Very low battery voltage alarm Outage no-priority load alarm Test battery alarm Temperature alarm Sensor alarm

MPI160HD TECHNICAL DESCRIPTION

4 OPTIONS

The MPI160HD system can have the following options installed. The available options are differentiated by their class.

Class	Equipment	Designation
Input protection	Mains Circuit Breaker	Mains circuit breaker up to 50A - 3 phases, C curve, for AC protection
	Division protection	1 circuit breaker 25A C curve per rectifier
	Surge Protection Device (SPD)	Surge protection Class C (type 2) – 3 phases
	Over-voltage Protection (OVP)	Input protection against over voltage
Output protection	Circuit breaker	Output circuit up to 100A
	Fuse	Output fuses up to 100A
	Load tripping fault board	Output Circuit Breaker alarm report
	Non-Priority Load Disconnect (LVDL)	Non-Priority Load disconnect contactor
Battery Protection	Circuit breaker	Battery circuit breaker protection (up to 4)
	Fuse	Battery fuse protection (up to 4)
	Low Voltage Battery disconnect override (LVDB) system	Low Voltage Battery Disconnect override switch
Communication	NCSI1000HD	Web server TCP/IP protocol
	PSTN Modem	PSTN protocol
	GSM	GSM protocol
	USB Interface	RS232/USB interface
Input & output extension	Digital input extension	Digital input extension board
	Digital output extension	Digital output extension board
Software	Menu managed on the PC	Wini1000 - Winsite

MPI160HD TECHNICAL DESCRIPTION

5 SYNOPTIC

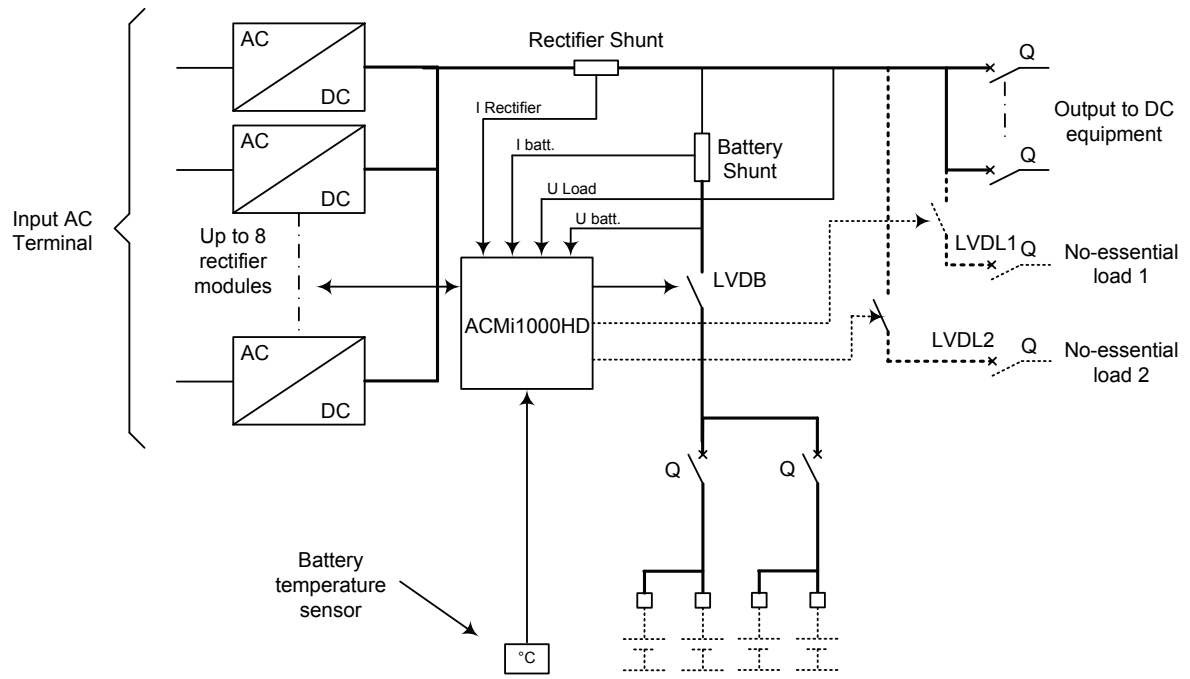

6 PACKAGING AND PRODUCT REFERENCE

6.1 PACKAGING

In carton.

6.2 PACKING TABLE

MPi160HD packed dimensions and weight			
B05366210000	W x D x H	mm	615 x 590 x 550
	Gross Weight	kg	30
	Volume	m ³	0.20
B05366110000	W x D x H	mm	615 x 590 x 680
	Gross Weight	kg	38
	Volume	m ³	0.25
B05366200000	W x D x H	mm	615 x 590 x 550
	Gross Weight	kg	29
	Volume	m ³	0.20

6.3 PRODUCT REFERENCE

Designation	H&S's Code
MPi160HD (Basic) 12U	B05366210000
MPi160HD (LVDL option) 8U	B05366110000
MPi160HD (SPD + OVP) 12U	B05366200000
MPi160HD (SPD + Division breakers+ LVDL) 12U	B05366170000
MPi160HD 8U	B05368440000
MPi160HD (Customized)	<i>Adapted to customer</i>

7 SUPPLIER

Harmer & Simmons
A division of AEG Power Solutions

10, rue Jean Perrin BP359
37173 Chambray Les Tours Cedex
FRANCE

Phone : 33 (0) 247 808 860

Fax : 33 (0) 247 280 719

Internet : www.harmerandsimmons.com

Harmer & Simmons offers installation, customization and technical support services.
Contact your local re-seller.

MPi160HD TECHNICAL DESCRIPTION

BN 44 1110/01

Ed : 01

Date : 05.11.09

8 / 8